

TECHNICAL REQUIREMENTS

1. DESIGN AND MANUFACTURE: API 6D
2. PRESSURE & TEMPERATURE RANK : ASME B16.34
3. THREADED END: NPT (ASME B1.20.1)
4. TEST & INSPECTION: API 598
5. 1" PLUG DESIGN

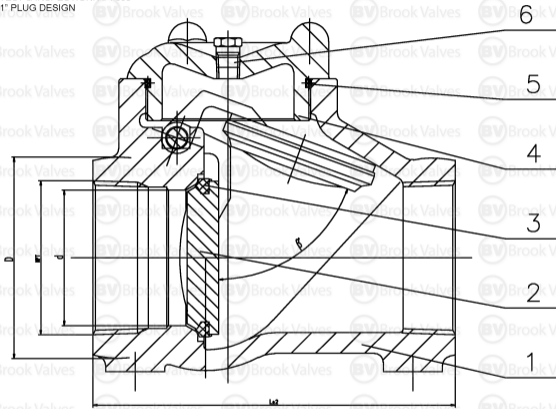

NO.	NAME	MATERIAL
1	BODY	ASTMA395 DI
2	DISC	ASTMA351 CF8
3	SEALING RING	VITON
4	BONNET	ASTMA395 DI
5	O-RING	VITON
6	PLUG	ASTMA105

SIZE	L	NPT	d
25	120	1" - 11.5 npt	25.4
50	152	2" - 11.5 npt	50.4
80	210	3" - 8 npt	78

REV A	BROOK VALVES	
DATE	DEC 2016	QZ614US
SCALE	TO FIT	
DUCTILE IRON FULL BORE CHECK VALVE NPT 2000 PSI CK		